

MATHEMATIZING THE CONCEPTUAL DESIGN PHASE: A CONCEPT GENERATOR BASED ON AN EMPIRICAL STUDY

Robert Stone*
Department of Basic Engineering

Zeke Strawbridge Daniel A. McAdams
Department of Mechanical Engineering

University of Missouri – Rolla
July 18, 2001

ABSTRACT

Design research has generated many computational tools to aid the designer over the years. Most of these tools are focused on either the preliminary steps of customer need gathering or the concluding steps of embodiment or detail design. The conceptual design phase has seen fewer computational tools even though well known methods are available such as brainstorming, intrinsic and extrinsic searches and morphological analysis. In this paper a generalized computational conceptual design tool is presented to aid designers at the conceptual design stage. It relies on storing and reusing existing design knowledge to create new concept variants. Concept variants are computed using matrix manipulations, essentially creating a mathematical morphological matrix. The concept generator produces quick concepts that can be used for concept selection or as a basis for generating additional concept variants through non-computational, creative techniques.

Keywords: conceptual design, functional modeling, computational design tools, morphological analysis

1. INTRODUCTION

1.1. MOTIVATION

Design research has generated many computational tools to aid the designer over the years. Most of these tools are focused on either the preliminary steps of customer need gathering (e.g., Quality Function Deployment) or the concluding steps of embodiment or detail design (e.g., Design Structure Matrices, graph grammars, solid models, dynamic modeling, Finite Element Analysis, etc.). The central part of the design process, which we call concept generation, has seen less generally applicable tools even though well known methods are available (e.g., brainstorming, intrinsic and extrinsic searches, morphological matrices, etc.).

Currently an engineer who wants to create a quality design has several options available. If the designer is experienced or works with experienced engineers, they could draw on their own knowledge or on the experience of others. However, relying only on knowledge

*Corresponding Author: 102A Basic Engineering Building; Rolla, MO 65409-0210; 573-341-4086; rstone@umr.edu

gained from one's own past experiences limits the design possibilities and biases the design process.

An engineer looking to meet certain design specifications could perform a patent search and locate a number of different or similar designs. Alternatively, they could reverse engineer a product to find out how it meets the design goals and seek to improve the design. Performing patent searches and reverse engineering products often proves to be a laborious activity. Design experience (non-proprietary) is essentially what the empirical study seeks to capture.

In this paper we report on a computational tool, called a concept generator, to assist a designer at the conceptual stage of design. The concept generator is developed from an empirical study of consumer products and is intended to help designers choose a correct component for a given function in a redesign or original design situation. The goal of the concept generator is to produce many concepts quickly and early in the design process by making use of existing design knowledge. Ultimately the concept generator approach is anticipated to reduce the number of iterations in the design process.

Existing *design knowledge* is extracted from simple consumer products by performing an empirical study. To be clear, we define *design knowledge* as the body of facts, principles or techniques accumulated by designers. This is not to be confused with *design information*, which we define as any design data or observations. Design knowledge refers to ideas inferred from information and represents an understanding of what is known about design. To store design knowledge, products are disassembled to record a bill of materials and the product's components are mapped to the functions they solve in the product. To reuse design knowledge, only a functional description of a product is necessary to quickly generate a list of components that solve the functions of the new design. As a brief example of the storage process, a Black and Decker staple gun's components are mapped to the functions they solve in Fig. 1.

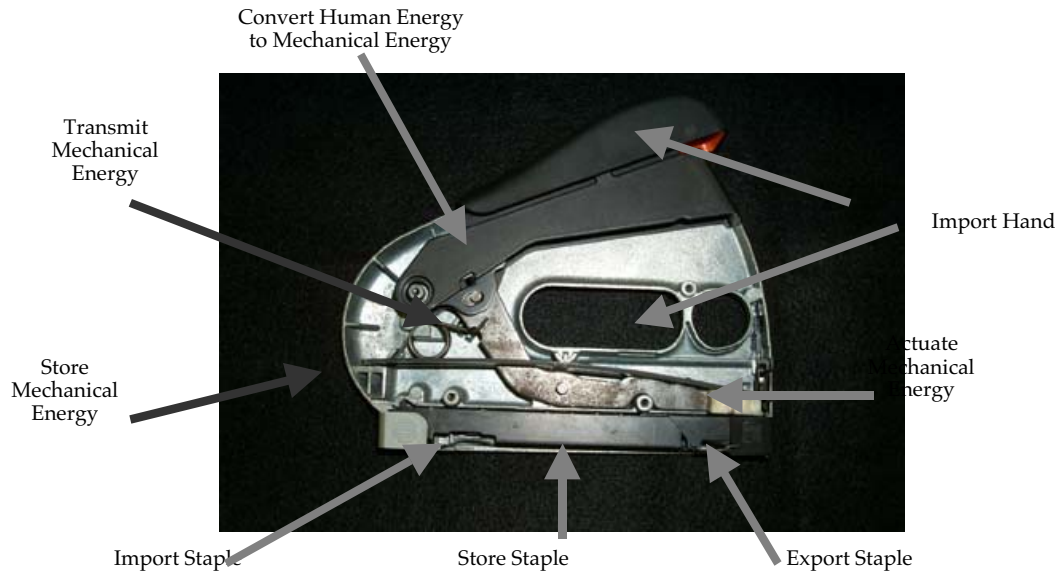

Figure 1. A Black & Decker staple gun with functions mapped to its components.

1.2. OVERVIEW

The next section presents a literature review of current design methods and outlines the need for the concept generator. Section 3 describes the empirical procedure and describes the research that leads to the concept generator. In Section 4 the concept generator is presented. Section 5 discusses the validation of the concept generator with the design of a spring surge demonstrator. Finally, conclusions are drawn from the validation.

2. RELATED WORK

2.1. PRESCRIPTIVE CONCEPTUAL DESIGN METHODS

Many researchers have sought to formalize, or prescribe, the conceptual design phase. Most rely on some form of functional decomposition of the overall problem to initiate the design [1-5]. The motivation is to produce a quality product that consumers will purchase. Pahl and Bietz [1] sum up this sentiment by stating “Quality cannot be achieved simply through testing and developing a product – it has to be built-in from the beginning of the design process and maintained throughout the production process.” This statement is justified by the fact that up to 80% of all faults can be traced back to insufficient planning and design work. Pahl and

Beitz feel that the best way to achieve quality is to take measures to avoid faults throughout the total product development process. This sentiment is echoed by other prescriptive approaches to design [2, 3, 4].

Jones [5] takes a different approach to design. He discusses the need for different methods, both new and traditional, and reviews new methods and strategies for choosing a method. Because Jones feels that there is no one correct design method it is up to the designer to select the right method and for that reason the designer should be well informed.

The Russian Theory of Inventive Problem Solving, TIPS or TRIZ, is another popular design method [6]. In an attempt to create a generic design methodology, Mann has merged TRIZ with other problem solving tools to create a comprehensive design methodology that works on a wide range of problems [7].

Scott and Antonsson [8] have written a paper, which outlines the application of the Method of Imprecision, developed by Wood and Antonsson [9], to vehicle structure design. This is useful in addressing the informal decisions that are made in preliminary design and the imprecise information between co-workers on a design team.

Stone and Wood have standardized the initial phase of the design process by formally deriving a functional model [10]. They outline the methods to take customer need information, create a black box, and then create a functional model, using a common language, which represents the function of a product in terms of sub-functions in verb-object form. Researchers at the National Institute of Standards and Technology are also working on a standardized method of representing product function as part of an overall representation of product data [11]. These two works have been reconciled by Hirtz et al. [23] to create a unified language of functions and flows to describe product functionality.

Decision based design is based on the idea that the design process is ultimately a set of decisions. There are limitations to this type of design as Thurston points out [12]. Real limitations to decision based design lie with the initial configuration and analytical design phases as well as the problems that arise in overcoming difficulties with group decision-

making. A paper by Wan and Krishnamurthy tries to solve some of these decision-making difficulties with comparison-based decision-making [13].

The House of Quality is a tool used in the design process, which relates customer needs to design requirement metrics. The metrics are related in a correlation matrix, which forms the roof of the house of quality. A method developed by Gauthier et al. attempts to implement optimization early in the design process, using the structured environment of the House of Quality [14].

2.2. EMPIRICAL STUDIES

McAdams and Wood have proposed a design method in their paper “Design by Analogy” [15], which takes the functional model a bit further. By referencing a database of product information, built from empirical studies, they compare what they want to design with what has already been designed.

The early stages of the design process contain much informal information related to engineering decisions. Wood et al. have created a language to attempt to capture design information [17]. They hope to capture design experience by recording life cycle design issues, design process terms and component and system functional decompositions.

A paper by Yen et al. [18] outlines the approach and analysis of an empirical study meant to support the hypothesis that concept generation and development occur in informal media and therefore current design tools do a poor job of capturing the information. The authors create ways of capturing this information and means to reuse design information with the help of a computer program.

In an attempt to bridge the gap between a novice designer and an expert, Ahmed et al. have performed a study to identify the information a novice engineer needs to gain experience faster [19]. A group of researchers in the United Kingdom set out to observe different groups of people with different experience levels performing conceptual design tasks [20]. A dozen main activities, to be shaped into a formal conceptual design process, are identified.

2.3. DESIGN TOOLS

Wang et al. [16], discuss the use of computer technology to automate the conceptual design process. The authors suggest that the entire design process could be automated if the conceptual design process could be automated. The authors then propose methods of conceptual design automation through the use of computers.

In a paper by Liu et al. [21], the issue of developing physical embodiments from a set of spatial configurations is addressed. Three steps are outlined which compose a method for transforming functional solutions to physical embodiments.

Stahovich created a computer program that observes iterative solutions to a parametric design problem and learns the design strategy involved [22]. The program can be used to generate solutions to other problems after learning a given designer's engineering judgment.

2.4. SUMMARY

To sum up, a multitude of methods exist to initiate the design process by first looking at a problem conceptually. While some of these methods are more algorithmic than others, no tool exists to transform a purely functional description of a product into a concept variant (or set of concepts). The work thus far sets the stage for a computational concept generation tool with broader applications.

3. AN EMPIRICAL COMPARISON STUDY OF PRODUCT PAIRS: PROCEDURE

3.1. THE NEED FOR AN EMPIRICAL METHODOLOGY

The concept generator relies on a design knowledge base, containing information on how existing products are designed. An empirical study of products is conducted to gather the initial design knowledge base. The premise of the study is that quality designs come from experienced designers. By recording existing design knowledge, it can be reused to help designers choose a high quality design in the simplest form, instead of choosing a poor design and pushing it until it works, often increasing the complexity of the product. Below, we outline our empirical approach to recording design knowledge for this research work.

3.2. EMPIRICAL RESEARCH APPROACH

Step 1: Derive each product's functional model. The first step is to gather the weighted customer needs for the product. This involves interviewing likely users of the product and recording their needs and relative importance. A black box model is created next. The black box model states the overall function of the product and identifies all flows in and out of the product. A functional model is then created using the functional basis [10]. Using the black box model, each flow is followed through the product. Each function that the product performs on each flow is listed in verb-object format. With the function model derived for product i , a $n \times 1$ product vector ϕ_i is constructed by listing the n sub-functions from the functional model. The product vector's elements ϕ_{ij} are a summation of each customer need weight associated with function j .

Step 2: Document product components. Next, the product is disassembled. A disassembly plan is created and a Bill of Materials (BOM) is recorded as the products are taken apart [3].

Step 3: Map components to function. As the products are taken apart, each part is mapped to its related sub-function from the functional model. For the empirical study to be effective, the function of every part must be determined. If a component function has been overlooked in Step 1, then the functional model is updated.

Step 4: Record the function-component matrix. The functional models are now double-checked to make certain that the sub-functions are defined properly and that all flows are accounted for. With the functional model set, a function-component matrix is made. A function-component matrix is a mathematical representation of the mapping between a product's components to its sub-functions.

The function-component matrix stores the relationships between a product, its components and its sub-functions. The product's m components represent the rows of the matrix and the product's n sub-functions represent the columns of the matrix. For one product, the $m \times n$ matrix elements would contain either a zero or a positive integer. A positive integer k

indicates that k components are used to solve that sub-function. A zero indicates no relation of component and sub-function. The matrices from several different components can be aggregated together. This involves combining the sub-functions columns when two products have the same sub-function and combining the component columns when two products have similar components. For example, a designer begins the design process for a new design or re-design. The designer can take the list of sub-functions from the functional model of their design, reference that list with the complete list of sub-functions from the merged function-component matrix, and get a list of components that could be utilized in the embodiment of their design.

4. THE CONCEPT GENERATOR: A COMPUTATIONAL TOOL FOR CONCEPTUAL DESIGN

The concept generator developed from the empirical study is aimed at the conceptual design stage, as illustrated in Fig. 2. A new (or redesigned) product's functional model is the input into the concept generator and product components are the output.

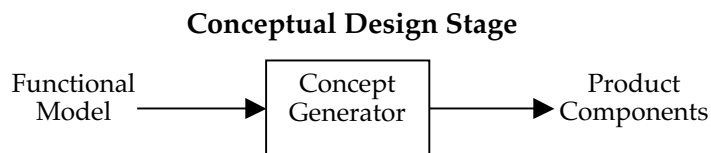

Figure 2. Concept Generator Flow Chart

4.1 CREATING THE CONCEPT GENERATOR'S ENGINE

Mathematically, the concept generator is a series of matrix manipulations that identify potential components for a new product based on the sub-functions from the product's functional model. The engine of the concept generator is the design knowledge captured in the function-component matrix, called the Chi Matrix (\mathbf{X}).

The product's components, as recorded in the Bill of Material from step 3 of the empirical study procedure (Section 3), are listed down the vertical axis of the matrix so that each component has a corresponding row. The sub-functions, listed from the product's functional

model (created in step 2, Section 3), are listed across the horizontal axis of the matrix so that each sub-function has a corresponding column. The matrix elements are filled with a zero if a component is not used to solve a given sub-function, or a positive integer indicating the number of components used to solve a given sub-function.

After multiple function-component matrices are made, they can be aggregated into a single matrix. The aggregated matrix is called the Chi Matrix and can be represented by \mathbf{X} . A standard categorization of components is created to combine similar components into a single row of \mathbf{X} . If more than one product has the same component, the matrix element χ_{ij} represents the cumulative number of times component i solves sub-function j . As more products are compared and more function-component matrices are created, the Chi Matrix will grow in size until the sub-functions reach an anticipated finite number.

4.2 FORMULATING THE CONCEPT GENERATOR

The input to the concept generator is a functional model of the new product to be designed. This functional model is created in the same manner as step 2 of Section 3. In addition to the functional model, a product vector for the new product is created as described in step 2.

The next step in using the concept generator is to create a filter matrix. The filter matrix, \mathbf{F}_k , is a diagonalized matrix with the same sub-functions headings for the rows and columns. The sub-function elements on the diagonal of the identity matrix contain a one if the new design has that sub-function or a zero if the new design does not. All other off-diagonal elements are zero.

For example, assume Fig. 3 to be the functional model of a new design and is to be referenced with the function-component matrix in Fig. 4. The filter matrix would look like Fig. 5.

When the function-component matrix is post-multiplied with the filter matrix, a suggested component matrix is created. The resulting matrix, \mathbf{M}_k , is a morphological matrix

that provides physical solutions for each sub-function. Equation (1) shows the multiplication of the two matrices. Fig. 6 is the morphological matrix from the simple design example.

$$\mathbf{X} \mathbf{F}_k = \mathbf{M}_k \tag{1}$$

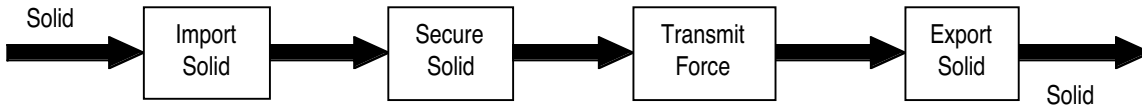

Figure 3. Simple Functional Model Example

	import solid	secure solid	transmit force	export solid	display disp.	change disp.	measure force	display signal
Cover	2	2	0	2	0	0	0	0
Coil spring	0	2	0	0	0	0	0	0
Steel bar/plate	0	0	2	0	0	0	0	0
Steel guide plate	0	0	1	0	0	0	0	0
Steel channel	0	0	2	0	0	0	0	0
Four-bar linkage	0	0	1	0	0	0	1	0
Thin steel plate	0	0	1	0	0	0	1	0
Triangular linkage	0	0	2	0	0	0	2	0
Number plate	0	0	0	0	0	0	0	1
Needle/cap	0	0	0	0	0	0	0	1
Dial	0	0	0	0	0	0	0	1
View Window	0	0	0	0	2	0	0	2
No skid pads	0	2	0	0	0	0	0	0

Figure 4. Function-Component Matrix Example.

	import solid	secure solid	transmit force	export solid	display disp.	change disp.	measure force	display signal
import solid	1	0	0	0	0	0	0	0
secure solid	0	1	0	0	0	0	0	0
transmit force	0	0	1	0	0	0	0	0
export solid	0	0	0	1	0	0	0	0
display disp.	0	0	0	0	0	0	0	0
change disp.	0	0	0	0	0	0	0	0
measure force	0	0	0	0	0	0	0	0
display signal	0	0	0	0	0	0	0	0

Figure 5. Filter Matrix Example.

	import solid	secure solid	transmit force	export solid	display disp.	change disp.	measure force	display signal
Cover	2	2	0	2	0	0	0	0
Coil spring	0	2	0	0	0	0	0	0
Steel bar/plate	0	0	2	0	0	0	0	0
Steel guide plate	0	0	1	0	0	0	0	0
Steel channel	0	0	2	0	0	0	0	0
Four-bar linkage	0	0	1	0	0	0	0	0
Thin steel plate	0	0	1	0	0	0	0	0
Triangular linkage	0	0	2	0	0	0	0	0
Number plate	0	0	0	0	0	0	0	0
Needle/cap	0	0	0	0	0	0	0	0
Dial	0	0	0	0	0	0	0	0
View Window	0	0	0	0	0	0	0	0
No skid pads	0	2	0	0	0	0	0	0

Figure 6. Example Morphological Matrix.

A morphological matrix is traditionally created by listing all of the sub-functions for a design and brainstorming solutions to each sub-function, listing the solutions as columns and the sub-functions as rows. The matrix resulting from the multiplication is the transpose of a traditional morphological matrix. The benefit of using the filter matrix with the chi matrix is that it makes the morphological matrix computational. Computing the matrix via multiplication provides quick generation of solution principles that can subsequently be augmented via brainstorming or other non-computational creative methods.

4.3 SECTION SUMMARY

The conceptual design process is made easier by the use of a concept generator. Having gathered the customer needs and created a functional model, a designer can obtain component suggestions for a new design by multiplying the chi matrix with a filter matrix based on the new design. The process is quick and does not require the efforts of an entire team. The matrix multiplication discussed in this section is the one of the first steps in making morphological matrices computable. Computing a morphological matrix is not a substitute for brainstorming to create one, but it is a simple way to create one and a step towards advancing the computability of a more complete morphological matrix.

5. VALIDATING THE CONCEPT GENERATOR

In this section the design of a new product is used to validate the concept generator. While one case study alone can not complete the validation process, it does give insight into the power of the concept generator as a computational tool. First the design problem will be outlined. The concept generator is then applied. Then suggested components are compiled and a design concept is presented.

The design of a spring surge demonstrator is used to validate the concept generator. A spring surge demonstrator is to be designed so that spring surge, or fluctuation in spring force due to repeated loads at a specific frequency can be shown to students in a classroom.

When a spring is compressed, the force that the spring provides is a function of how much the spring is compressed. For example, a spring with $K = 200 \text{ lb/ft}$ is compressed 6 in. The force that spring provides at that displacement is 100 lb. When the spring is repeatedly loaded and unloaded at high enough frequencies, a traveling wave develops within the spring. This wave is referred to as spring surge. When a wave is present, it causes fluctuations in the spring force reading. If the fluctuations can be measured, then spring surge can be measured and demonstrated.

First the customer needs are gathered. Based on the needs of the instructors, seven customer needs were recorded. Using the customer needs for the spring surge demonstrator, the material, energy and signal flows in and out of the product are identified. Also the overall product function is defined, demonstrate spring surge. The flows in and out of the overall product function comprise the black box model and can be seen in Fig. 7.

Then next step in the design process is to create the function model as per step 2 of Section 3. The functional model for the spring surge demonstrator appears in Fig. 8.

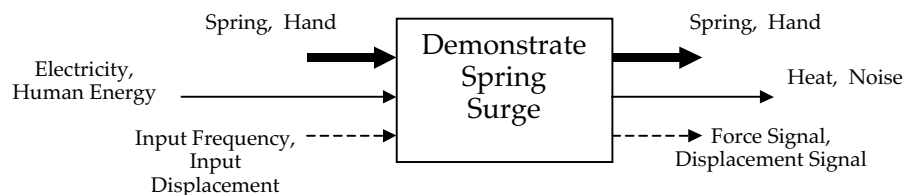

Figure 7. Spring Surge Demonstrator Black Box Model.

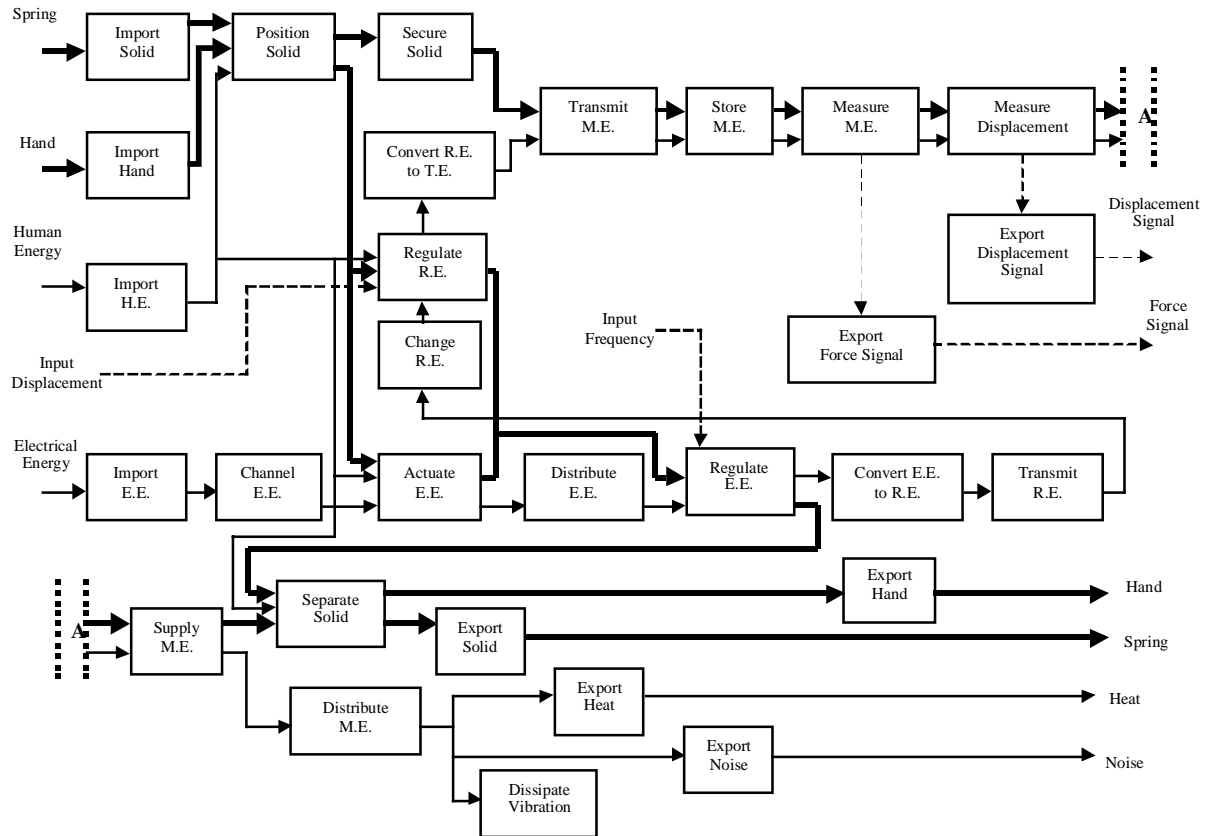

Figure 8. Spring Surge Demonstrator Functional Model.

With all of the sub-functions identified, the sub-functions are cross-referenced with those in the Chi Matrix. The functional model for the spring surge demonstrator has 29 sub-functions total. Of those 29 sub-functions, 26 match the sub-functions in \mathbf{X} (constructed from a study of 18 consumer products).

The 26 sub-functions that match are used to create the filter matrix, \mathbf{F}_k placing a value of one on the diagonal of the matrix if the sub-function is present. \mathbf{X} and \mathbf{F}_k are multiplied to obtain the suggested component morphological matrix, \mathbf{M}_k . The components with values greater than 2 are compiled. A total of 31 components were suggested based on the sub-functions of the spring surge demonstrator.

Figure 9 shows the condensed suggested component matrix, \mathbf{M}_k . Only the sub-functions that matched the functional model and the primary suggested components are included.

Component	import solid	secure solid	Position solid	separate solid	export solid	display displacement	display signal	dissipate thermal e.	transmit m.e.	distribute m.e.	store m.e.	import hand	export hand	import human energy	change rotation	regulate rotation	transmit rotation	convert r.e. to translation	measure force	import electricity	channel electricity	actuate electricity	regulate electricity	convert ee to re	dissipate acoustic energy	dissipate vibration
Cover / Casing	11	9	0	2	7	0	2	2	0	4	0	5	2	3	0	0	0	0	0	0	0	0	0	0	3	3
Steel bar/plate	5	8	0	1	5	0	0	3	7	4	3	0	0	3	0	0	0	0	1	0	0	0	0	1	2	2
Spring Support	0	0	0	0	1	0	0	0	3	0	2	0	0	0	0	0	0	0	0	0	0	0	0	0	0	0
Coil spring (comp.)	1	1	0	2	4	0	0	1	5	0	2	0	0	1	0	0	0	0	2	0	0	3	0	0	0	0
Coil spring (tension)	2	3	0	1	1	0	2	0	0	0	0	0	0	0	0	0	0	0	2	0	0	1	1	0	0	0
Torsion Spring	0	0	0	0	0	0	0	0	2	0	2	0	2	0	0	0	0	0	0	0	0	0	0	0	0	0
Leaf Spring	1	1	0	0	1	0	0	0	1	0	1	0	0	0	0	0	0	0	0	0	0	0	0	0	0	0
Triangular linkage	0	0	0	0	0	0	0	0	2	0	0	0	0	0	0	0	0	0	2	0	0	0	0	0	0	0
View Window	0	0	0	0	0	2	2	0	0	0	0	0	0	0	0	0	0	0	0	0	0	0	0	0	0	0
Handle / Hand grip	1	0	0	0	0	0	0	0	4	0	7	3	7	0	0	0	0	0	0	0	0	0	0	0	0	0
Screw	0	4	0	0	0	0	0	1	2	4	0	0	0	2	0	0	0	0	0	1	0	0	0	1	2	3
Nut	0	2	0	1	0	0	0	0	0	2	0	0	0	0	0	0	0	0	0	1	0	0	0	0	0	0
lock washer	0	1	0	0	0	0	0	0	0	2	0	0	0	0	0	0	0	0	0	0	0	0	0	0	0	0
Sleeve / Collar	0	0	0	2	0	0	0	0	1	0	0	0	0	0	0	0	0	0	0	0	0	0	0	0	0	0
Linkage	0	0	0	0	0	0	0	0	0	2	2	0	0	2	0	0	0	0	0	0	0	0	0	0	0	0
electrical switch	0	0	0	0	0	0	0	0	0	0	0	0	0	0	0	0	0	0	0	1	0	12	7	0	0	0
Electric Motor	0	0	0	0	0	0	0	0	0	0	0	0	0	0	0	0	0	0	0	1	0	0	0	10	1	0
wires	0	0	0	0	0	0	0	0	0	0	0	0	0	0	0	0	0	0	2	2	0	2	0	0	0	0
drive gears	0	0	0	0	0	0	0	0	0	0	0	0	0	0	2	2	2	0	0	0	0	0	0	0	0	0
spring clip	0	1	0	0	0	0	0	0	2	0	0	0	0	0	0	0	0	0	0	0	0	0	0	0	0	1
retainer pin	2	2	0	3	2	0	0	0	0	0	0	0	0	0	0	0	0	0	0	0	0	0	0	0	0	0
Filter holder	3	3	0	0	0	0	0	0	0	0	0	0	0	0	0	0	0	0	0	0	0	0	0	0	0	0
cutting blade	0	1	0	9	2	0	0	0	5	0	0	0	0	0	0	0	0	0	0	0	0	0	0	0	0	0
plastic switch	0	0	0	1	0	0	0	0	2	0	0	0	0	0	0	0	0	0	0	0	0	1	0	0	0	0
transmission guide	0	1	0	0	1	0	0	1	2	0	0	0	0	0	0	0	0	0	0	0	0	0	0	0	0	0
holder	1	2	0	3	1	0	0	0	2	0	0	0	0	0	0	0	0	0	0	0	0	0	0	0	0	0
foam	0	0	0	0	0	0	0	0	0	2	0	0	0	0	0	0	0	0	0	0	0	0	0	0	0	3
clear barrel	1	2	0	0	1	0	0	0	0	0	0	0	0	0	0	0	0	0	0	0	0	0	0	0	0	0
retaining ring	1	2	0	1	1	0	0	0	0	0	0	0	0	0	0	0	0	0	0	0	0	0	0	0	0	0
circuit board	0	0	0	0	0	0	0	0	0	0	0	0	0	0	0	0	0	0	0	2	2	0	0	0	0	0
brake caliper	2	0	0	2	2	0	0	0	0	2	0	0	2	0	0	0	0	0	0	0	0	0	0	0	0	0

Figure 9. Morphological Matrix for a Spring Surge Demonstrator

The suggested component matrix shown in Fig. 9 is essentially a morphological matrix for the design. Computing the morphological matrix is much faster than the traditional way of creating a morphological matrix by brainstorming in a group to generate ideas, but is not intended to be a substitute. A designer still needs to apply design principles to the suggested components to form them into the product being designed. Figure 10 shows the conversion of the primary suggested components to the components used in the new design. The concept generator is an advantageous design tool because it allows a designer to move from customer needs to concept generation and onto embodiment quickly. With the computed morphological

matrix, concept variants can be formed and standard selection methods employed to select a final concept to embody. The components for the spring surge demonstrator have been arranged into a design concept shown in Fig. 11, one of many possible from the computed morphological matrix.

Sub-Function	Suggested Component	Embodied Component
Import/Export Solid Secure/Separate Solid Import/Export Hand	Cover/Casing	Spring Cylinder/Product Base
Secure Solid Transmit Mechanical Energy	Steel bar/plate	Mechanical Linkages
Display Displacement Display Signal	View Window	Plastic Safety Cover
Import/Export Hand	Handle/Hand Grip	Linkage Adjustment Controls
Transmit Mechanical Energy Distribute Mechanical Energy	Linkage	Mechanical Linkages
Actuate Electricity	Electrical Switch	Electrical Switch
Convert Electrical Energy to Rotational Energy	Electric Motor	Electric Motor
Import Electricity Channel Electricity	Wires	Wires
Change Rotation Regulate / Transmit Rotation	Drive Gears	Drive Gears

Figure 10. Suggested Components verses Embodied Components

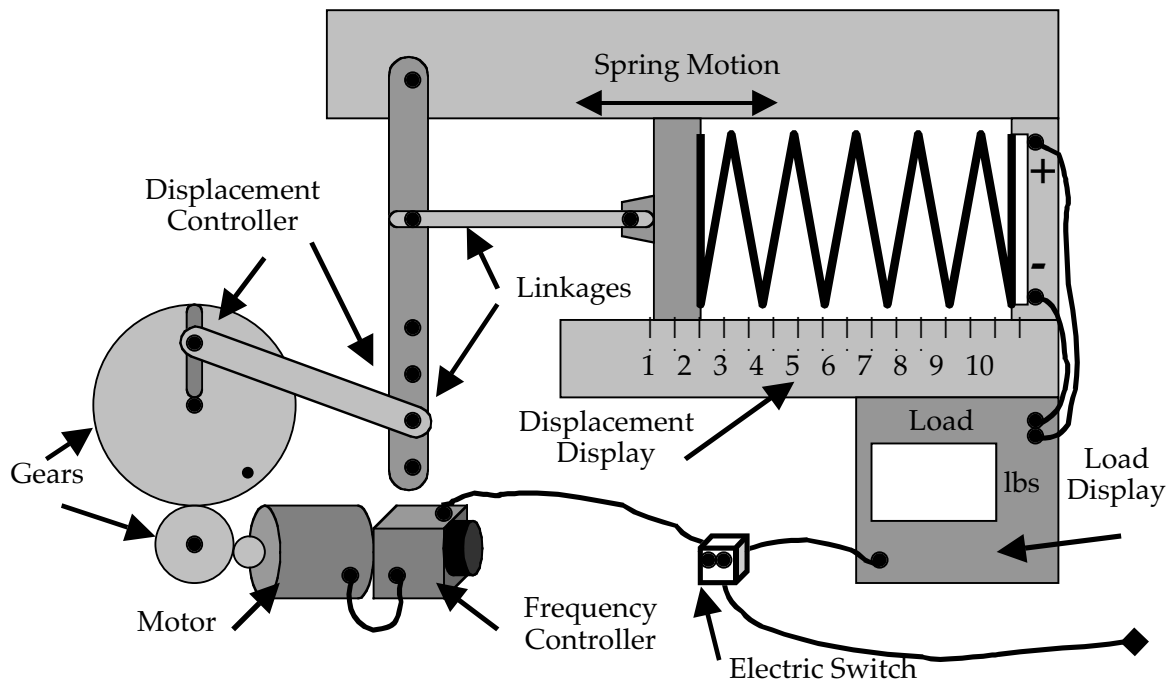

Figure 11. Embodied Design Concept for a Spring Surge Demonstrator

5. CONCLUSIONS

The literature review shows that research to quantify and formalize the conceptual phase of design is ongoing but not yet mature. Other empirical studies have examined the information flow of designers and make attempts at recording design information. The empirical study outlined here is crucial for the development of the design knowledge base needed to develop a concept generator. The functional models and bill of materials for the products examined are used to create function-component matrices. The matrices are aggregated into one function-component matrix, known as the chi matrix, which serves as the engine for the concept generator. It has been shown that a designer can take new design information, in the form of a functional model, and enter it into the concept generator to obtain suggested components for a new design. One validation case study shows the concept generator approach to quick generation of product concepts.

The conceptual design process is made easier by the use of the concept generator. The process is quick and does not require the efforts of an entire team. It demonstrates that the creation of a morphological matrix is a computable process. This is an important first step in automating the conceptual design process. The concept generator passes suggested components on to the embodiment design stage.

The concept generator represents a significant advance in methods to generate and embody design concepts starting with only a functional description. The design knowledge base allows a designer to get to the embodiment design stage quickly and with reduced design iterations. The designer can apply their engineering skills to the design concept and fabricate a prototype model.

To make the concept generator a more effective tool, more product information needs to be recorded and added to the product design knowledge base. More products will allow the chi matrix to grow in size, increasing the effectiveness of using the matrix. Also, different forms of design *information* that can be encoded in the chi matrix need to be examined. Currently, the

chi matrix records frequency of occurrence for a particular component solution. That information could be augmented with measures of quality, manufacturing and assembly ease or recyclability measures, for instance. Other future work includes creating a computational conceptual design tool to automate the design knowledge storage and the concept generator computation.

ACKNOWLEDGEMENTS

This work is supported by the National Science Foundation under grant DMI-9988817. Any opinions or findings of this work are the responsibility of the authors, and do not necessarily reflect the views of the sponsors or collaborators.

BIBLIOGRAPHY

- [1] Pahl, G. and W. Beitz, "Engineering Design: A Systematic Approach," Springer, London, 1996.
- [2] Ulrich, K. and S. Eppinger, "Product Design and Development," McGraw-Hill, 1995.
- [3] Otto, K., and K. Wood, "Product Design: Techniques in Reverse Engineering and New Product Development," Prentice Hall, Upper Saddle River, New Jersey, 2001.
- [4] Ullman, D., "The Mechanical Design Process," McGraw-Hill, 1997.
- [5] Jones, J., "Design Methods," David Fulton Publishers, London, 1987.
- [6] Altshuller, G., "Creativity as an Exact Science," Gordon and Branch Publishers, Luxembourg, 1984.
- [7] Mann, D., "Towards a Generic Systematic Problem Solving and Innovative Design Methodology," Proc. ASME Design Theory and Methodology Conference, DETC2000/DTM-14566, 2000.
- [8] Scott, M., and E. Antonsson, "Preliminary Vehicle Structure Design: An Industrial Application of Imprecision in Engineering Design," Proc. ASME Design Theory and Methodology Conference, DETC98/DTM-5646, 1998.
- [9] Wood, K., and E. Antonsson, "Computations with Imprecise Parameters in Engineering Design: Background and Theory," ASME Journal of Mechanisms, Transmissions, and Automation in Design, Vol.111, (No. 4), pp.616-625, 1989.
- [10] Stone, R., and K. Wood, "Development of a Functional Basis for Design," Journal of Mechanical Design, Vol. 122, (No. 4), pp.359-370, 2000.
- [11] Szykman, S., J. Racz, and R. Sriram, "The Representation of Function in Computer-Based Design," Proc. ASME Design Theory and Methodology Conference, DETC99/DTM-8742, 1999.
- [12] Thurston, D., "Real and Perceived Limitations to Decision Based Design," Proc. ASME Design Theory and Methodology Conference, DETC99/DTM-8750, 1999.
- [13] Wan, J., and S. Krishnamurty, "Comparison-Based Decision Making in Engineering Design," Proc. ASME Design Theory and Methodology Conference, DETC99/DTM-8746, 1999.
- [14] Gauthier, B., M. Sodhi, and P. Dewhurst, "On Optimization Methods in the House of Quality: Facilitating the Early Stage of Product Design," Proc. ASME Design Theory and Methodology Conference, DETC2000/DTM-14564, 2000.
- [15] McAdams, D., and K. Wood, "Quantitative Measures for Design by Analogy," Proc. ASME Design Theory and Methodology Conference, DETC2000/DTM-14562, 2000.

- [16] Wang, Q., M. Rao, and J. Zhou, "Intelligent Systems Approach to Conceptual Design," *International Journal of Intelligent Systems*, vol 10 num 3, March 1995.
- [17] Wood, W., M. Yang, M. Cutkosky, and A. Agogina, "Design Information Retrieval: Improving Access to the Informal Side of Design," *Proc. ASME Design Theory and Methodology Conference, DETC98/DTM-5665*, 1998.
- [18] Yen, S., R. Fruchter, and L. Leifer, "Facilitating Tacit Knowledge Capture and Reuse in Conceptual Design Activities," *Proc. ASME Design Theory and Methodology Conference, DETC99/DTM-8781*, 1999.
- [19] Ahmen, S., L. Blessing, and K. Wallace, "The Relationships Between Data, Information and Knowledge Based on a Preliminary Study of Engineering Designers," *Proc. ASME Design Theory and Methodology Conference, DETC99/DTM-8754*, 1999.
- [20] Girod, M., A. Elliott, I. Wright, and N. Burns, "Activities in Collaborative Concept Selection Processes for Engineering Design," *Proc. ASME Design Theory and Methodology Conference, DETC2000/DTM-14548*, 2000.
- [21] Liu, Y., A. Chakrabarti, and T. Bligh, "Transforming Functional Solutions into Physical Solutions," *Proc. ASME Design Theory and Methodology Conference, DETC99/DTM-8768*, 1999.
- [22] Stahovich, T., "LearnIT: A System That Can Learn and Reuse Design Strategies," *Proc. ASME Design Theory and Methodology Conference, DETC99/DTM-8779*, 1999.
- [23] Hirtz, J., R. Stone, D. McAdams, S. Szykman, and Wood, K., "Evolving a Functional Basis for Engineering Design," *Proceedings of DETC2001, DETC2001/DTM-21688*, Pittsburgh, PA, 2001.